

2x2 Polarization Maintaining Optical Circulator



Features

High Isolation
High Extinction Ratio
Low Insertion Loss
Excellent Environment Stability

Applications

Polarization Mode Dispersion Compensator
EDFA & Raman Amplifier
Coherent Telecommunication Systems
Fiber Optic Sensor

Specifications

Parameter	Unit	Values	
		Type A	Type B
Type			
Center Wavelength	nm	1310 or 1550	
Operating Wavelength Range	nm	± 30	± 20
Min. Isolation at 23°C	dB	40	20
Typ. Isolation	dB	50	30
Peak Isolation	dB	55	40
Typ. Insertion Loss	dB	0.8	0.7
Max. Insertion Loss	dB	1.1	1.0
Min. Return Loss	dB	55	
Min. Extinction Ratio	dB	20	20
Min. Cross Talk (Port 1 to Port 3, Port 2 to Port 4)	dB	50	
Max. Optical Power (CW)	mW	500	
Max. Tensile Load	N	5	
Fiber Type		PM Panda Fiber	
Operating Temperature	°C	-5 to +70	
Storage Temperature	°C	-40 to +85	

*Above specifications are for device without connector.

*For devices with connectors, IL will be 0.3dB higher, RL will be 5dB lower, and ER will be 2dB lower.

*The transmission optical path of A type is different from B type: A type: 1 -> 2, 2 -> 3, 3 -> 4; B type: 1 -> 2, 2 -> 3, 3 -> 4, 4 -> 1.

*The PM fiber and the key are aligned to the slow axis and fast axis is blocked.

Package Dimensions

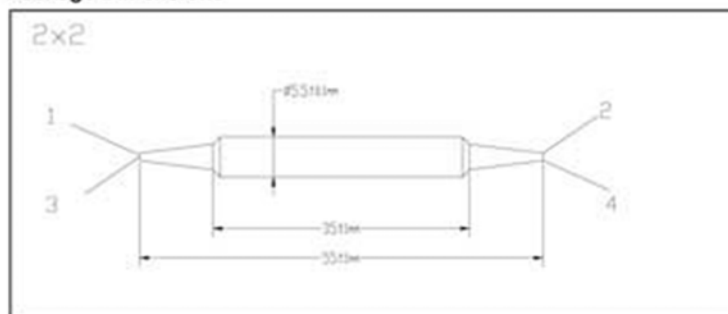

Ordering Information

PM CIR-①①-②-③-④④④④-⑤⑤⑤⑤-⑥

①①: Wavelength

31 - 1310nm
55 - 1550nm
SS- Specify

②: Type

A - Type A
B - Type B

③: Port

2 - 2x2

④④④④: Connector Type on Port 1, 2, 3 & 4

1 - FC/UPC
2 - FC/APC
3 - SC/UPC
4 - SC/APC
N - None
S - Specify

⑤: Fiber Length

0.8 - 0.8m
S - Specify

⑤⑤⑤⑤: Fiber Jacket on Port 1, 2, 3 & 4

B - 250um Bare Fiber
D - 400um Bare Fiber
L - 900um LooseTube
S - Specify