



## Features

Wide Pass Band  
 Low Insertion Loss  
 High Return Loss  
 Excellent Environmental Stability

## Applications

Fiber Lasers  
 Fiber Amplifiers  
 Fiber Sensors  
 Research

## Specifications

Parameters	Unit	Values	
Pass Band	Wavelength Range	nm	1550+/-20
	Max. Insertion Loss	dB	0.7
	Typ. Insertion Loss	dB	0.5
	Min. Isolation	dB	20
	Typ. Isolation	dB	25
Reflection Band	Wavelength Range	nm	1064+/-10
	Max. Insertion Loss	dB	0.7
	Typ. Insertion Loss	dB	0.5
	Min. Isolation	dB	12
	Typ. Isolation	dB	15
Min. Return Loss	dB	50	
Min. Directivity(over 1064+/-10nm)	dB	55	
Min. Extinction Ratio	dB	20	
Typ. Extinction Ratio	dB	22	
Thermal Stability	dB/°C	≤0.005	
Max. Optical Power (CW)	mW	300	
Max. Tensile Load	N	5	
Fiber Type		PM 1550 Panda Fiber for Port 3, PM 980 Panda Fiber for Ports 1/2	
Operating Temperature	°C	-5 to +70	
Storage Temperature	°C	-40 to +85	

\*Above specifications are for device without connector.

\*For devices with connectors, IL will be 0.3dB higher, ER will be 2dB lower and RL will be 5dB lower.

\*The PM fiber and the connector key are aligned to the slow axis.

## Package Dimensions

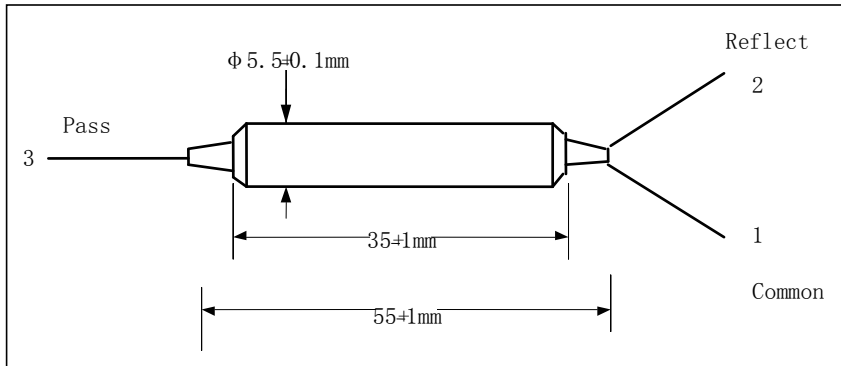

## Ordering Information

PMFWDM-①①①①-②②②-③③③-④

①①①①: Wavelength

5506 - 1550nm Pass / 1064nm Reflect

③③③: Fiber Jacket on Port 1, 2 & 3

B - 250um Bare Fiber

L - 900um Loose Tube

S - Specify

②②②: Connector Type on Port 1, 2 & 3

1 - FC/UPC

2 - FC/APC

3 - SC/UPC

4 - SC/APC

N - None

S - Specify

④: Fiber Length

0.8 - 0.8m

S - Specify