

Polarization Maintaining Filter Wavelength Division Multiplexer



Features

Wide Pass Band
 Low Insertion Loss
 High Return Loss
 Excellent Environmental Stability

Applications

Fiber Lasers
 Fiber Amplifiers
 Fiber Sensors
 Research

Specifications

Parameters		Unit	Values
Pass Band	Wavelength Range	nm	960~990 (1020~1080)
	Max. Insertion Loss	dB	0.7
	Typ. Insertion Loss	dB	0.5
	Min. Isolation	dB	25
	Typ. Isolation	dB	30
Reflection Band	Wavelength Range	nm	1020~1080 (960~990)
	Max. Insertion Loss	dB	0.5
	Typ. Insertion Loss	dB	0.3
	Min. Isolation	dB	12
	Typ. Isolation	dB	15
Min. Return Loss		dB	50
Min. Extinction Ratio		dB	20
Typ. Extinction Ratio		dB	22
Min. Directivity (over Reflection Band)		dB	55
Thermal Stability		dB/°C	≤0.005
Max. Optical Power (CW)		mW	300
Max. Tensile Load		N	5
Fiber Type			PM 980 Panda Fiber
Operating Temperature		°C	-5 to +70
Storage Temperature		°C	-40 to +85

*Above specifications are for device without connector.

*For devices with connectors, IL will be 0.3dB higher, ER will be 2dB lower and RL will be 5dB lower.

*The PM fiber and the connector key are aligned to the slow axis.

Package Dimensions

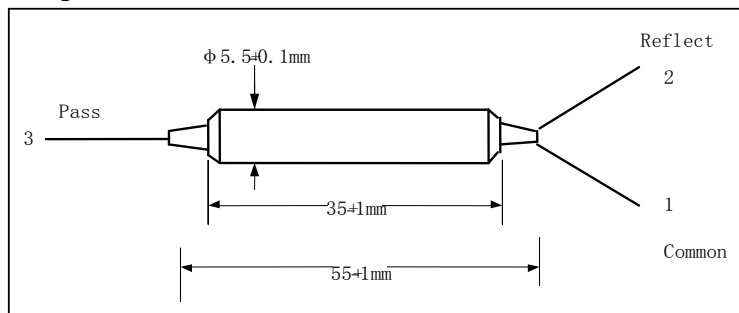

Ordering Information

PMFWDM-①①①①-②②②-③③③-④

①①①①: Wavelength

9806 - 980nm Pass / 1064nm Reflect

0698 - 1064nm Pass / 980nm Reflect

③③③: Fiber Jacket on Port 1, 2 & 3

B - 250um Bare Fiber

L - 900um Loose Tube

S - Specify

②②②: Connector Type on Port 1, 2 & 3

1 - FC/UPC

2 - FC/APC

3 - SC/UPC

4 - SC/APC

N - None

S - Specify

④: Fiber Length

0.8 - 0.8m

S - Specify